

What is the general power of energy storage battery containers



Overview

Energy battery containers offer a flexible and efficient solution for managing various energy needs across diverse sectors. With numerous advantages like mobility, high storage capacity, and scalability, these containers are poised to play a critical role in energy storage and. Battery storage is a technology that enables power system operators and utilities to store energy for later use. A battery energy storage system (BESS) is an electrochemical device that charges (or collects energy) from the grid or a power plant and then discharges that energy at a later time to. By definition, a battery energy storage system (BESS) is an electrochemical apparatus that uses a battery to store and distribute electricity. discharging the electricity to its end consumer. These systems are designed to store energy from renewable sources or the grid and release it when required.

What is the general power of energy storage battery containers

SUPPORT REAL-TIME ONLINE MONITORING OF SYSTEM STATUS



Battery energy storage system

As of 2021, the power and capacity of the largest individual battery storage system is an order of magnitude less than that of the largest pumped-storage power plants, the most common form of grid ...

[Learn More](#)

How a Containerized Battery Energy Storage System Can Improve ...

Container energy storage solutions are becoming integral to modern energy infrastructures due to their ability to address key energy challenges. One of the primary functions of a ...

[Learn More](#)

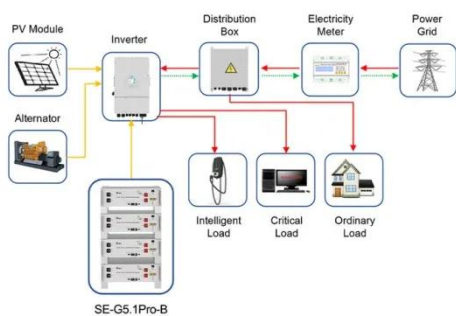

Application scenarios of energy storage battery products

Energy storage: what it is and how it works , Enel Group

Electricity stored in BESS can be used in a number of situations. First and foremost, to balance demand fluctuations and synchronize them with intermittent generation from renewable sources.

[Learn More](#)

Battery Containers for Large-Scale

Energy Storage

A battery container is a robust and scalable solution for large-scale energy storage. It enables organisations to store and deploy energy at the scale required for modern energy infrastructure, from ...

[Learn More](#)



Battery energy storage system

Overview Construction Safety Operating characteristics Market development and deployment

A battery energy storage system (BESS), battery storage power station, battery energy grid storage (BEGS) or battery grid storage is a type of energy storage technology that uses a group of batteries in the grid to store electrical energy. Battery storage is the fastest responding dispatchable source of power on electric grids, and it is used to stabilise those grids, as battery storage can transition from standby to full power in u...

[Learn More](#)

Containerized Battery Energy Storage System (BESS): 2024 Guide

Containerized Battery Energy Storage Systems (BESS) are essentially large batteries housed within storage containers. These systems are designed to store energy from renewable ...



[Learn More](#)

Understanding the Energy Capacity and Applications of BESS ...

Energy capacity is the total amount of electricity that a BESS container can store and later discharge. It is measured in kilowatt-hours (kWh) or megawatt-hours (MWh). This value reflects ...

[Learn More](#)

An In-Depth Look at Energy Battery Containers

Energy battery containers offer a flexible and efficient solution for managing various energy needs across diverse sectors. With numerous advantages like mobility, high storage ...

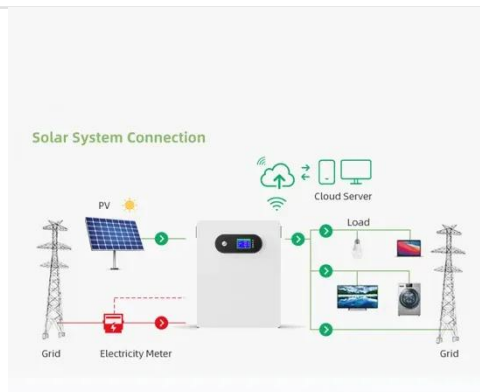
[Learn More](#)

Grid-Scale Battery Storage: Frequently Asked Questions

Battery storage is one of several technology options that can enhance power system flexibility and enable high levels of renewable energy integration.

[Learn More](#)

What are battery energy storage containers? , NenPower

One of the cornerstones of battery energy storage containers is the technology that powers them. Lithium-

ion batteries have emerged as the dominant technology due to their high ...

[Learn More](#)

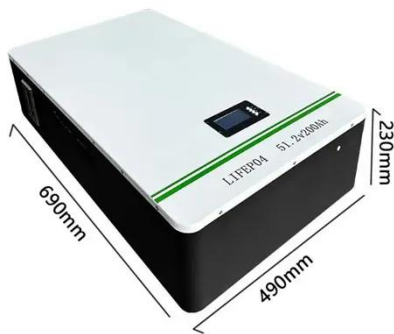

AN INTRODUCTION TO BATTERY ENERGY STORAGE ...

During peak demand hours, battery storage systems can be discharged to regulate, balance, and stabilize the energy grid. By charging batteries during periods of low customer consumption, co-ops, ...

[Learn More](#)

Contact Us

For catalog requests, pricing, or partnerships, please visit:
<https://www.v4venison.co.za>

